

### §10. Component part list and control circuit diagram

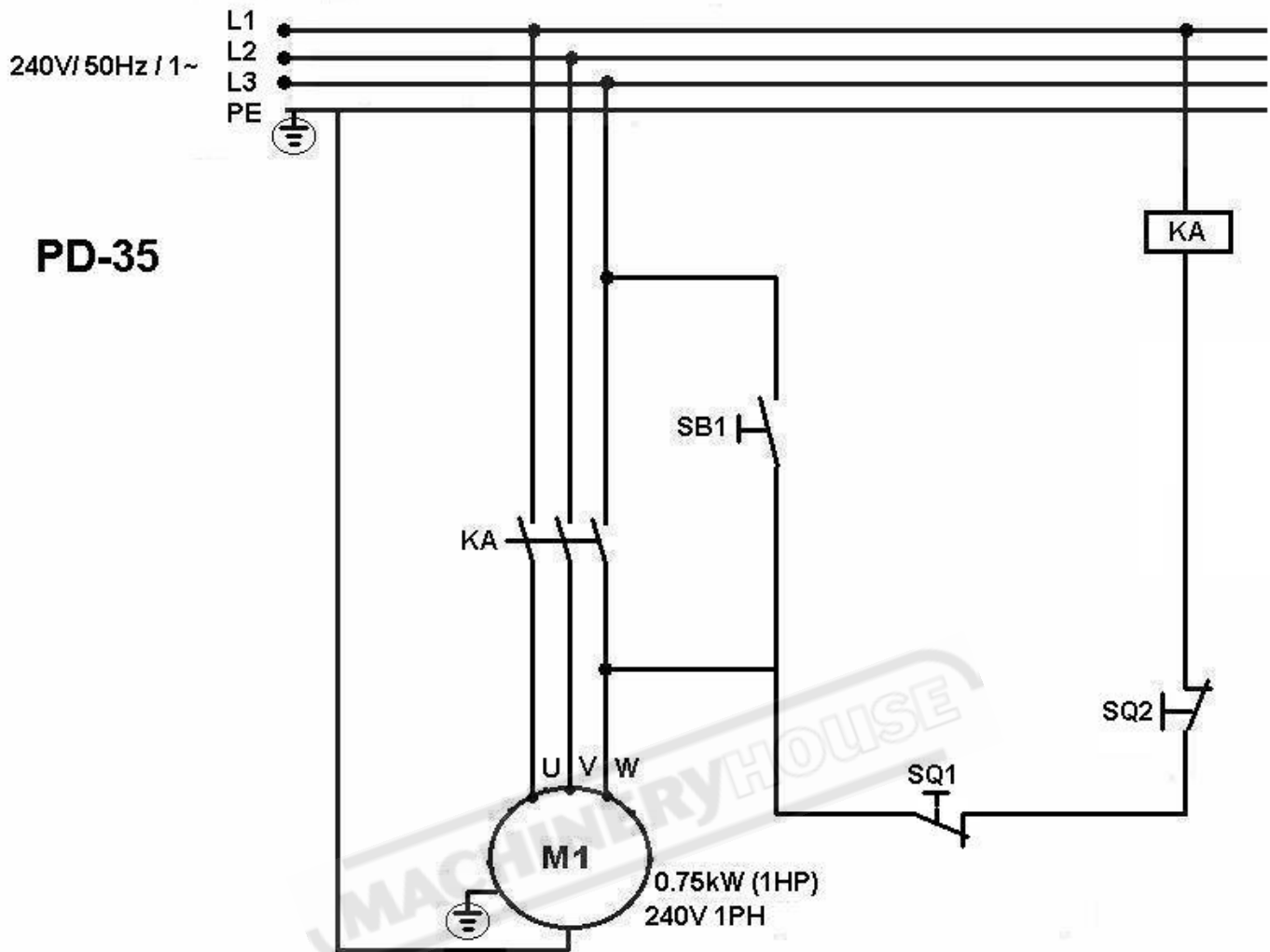

### PARTS LIST

### PD-35

Part No.	Component/ Object	Type/ Model	Ratings/ Technical Data	Pcs	Complies with the following standard	Marks of conformity granted
M1	MOTOR	PD-35	0.75kW/240V 50Hz/1PH	1	EN60034-1	CE
KA	CONTACT RELAY	JD3	AC 230V 16A	1	EN60947-4-1 EN60947-5-1	CE
SQ1	LIMIT SWITCH	VS10N	AC 250V 10A	1	EN61058-1	
SQ2	MICRO SWITCH CHUCK GUARD	VS10N	AC 250V 10A	1	EN61058-1	
SB1	EMERGENCY STOP	ALEPB25 -1/C	INC AC 250V, 3A	1	IEC 144	CSA CE LR108205-2

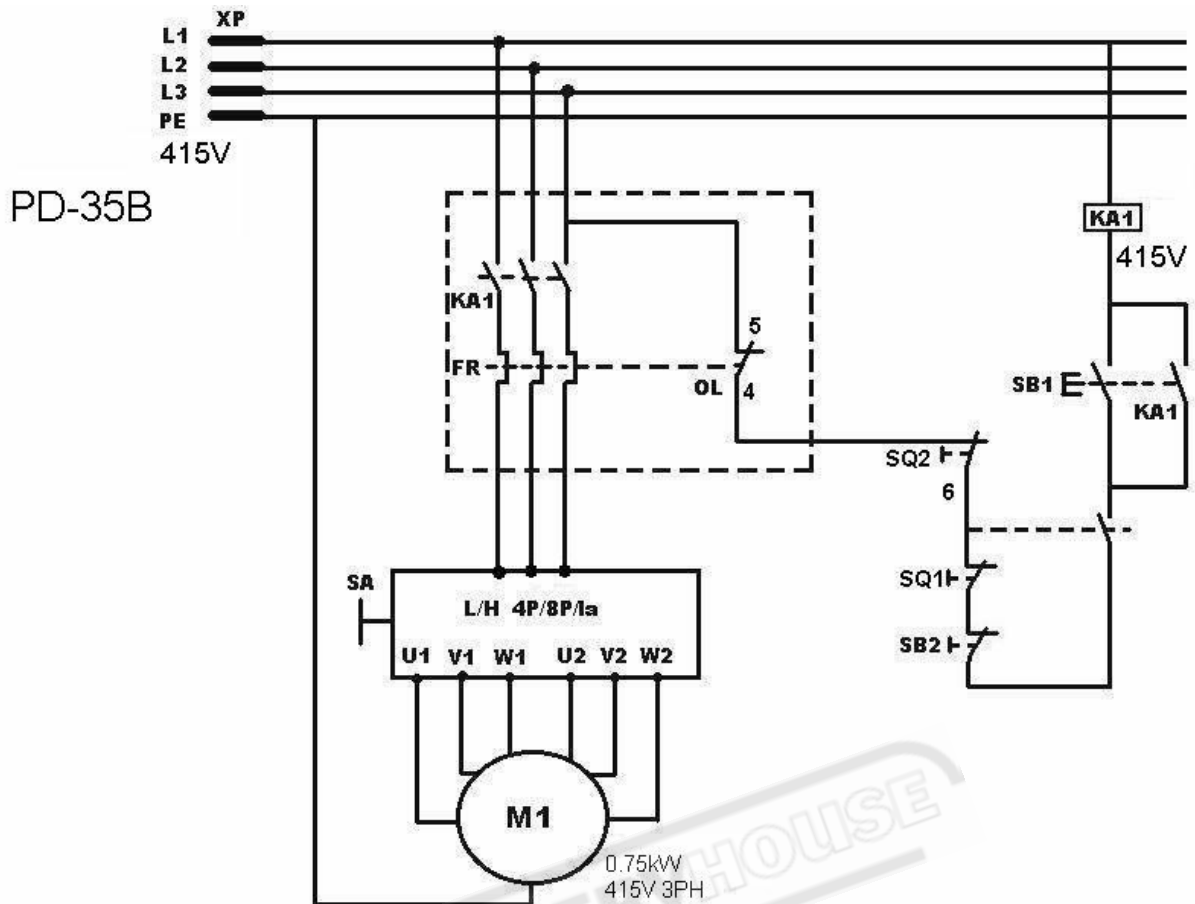

## PARTS LIST

## PD-35B

Part No.	Component/ Object	Type/ Model	Ratings/ Technical Data	Pcs	Complies with the following standard	Marks of conformity granted
M1	MOTOR	PD-35B	0.75kW/415V 50Hz/3PH	1	EN60034-1	
KA1	MAGNETIC CONTACTOR	CU-11	415V/24A	1	EN60947-4-1	CSA CE UL
FR	SERIES OVERLOAD RELAY	RHU-10K1	2.3-3.2A	1	EN60947-4-1	CSA CE UL
SQ1	LIMIT SWITCH	VS10N	AC 250V 10A	1	EN61058-1	
SQ2	MICRO SWITCH CHUCK GUARD	VS10N	AC 250V 10A	1	EN61058-1	
SB1	PUSH BUTTON	ABF-22-1A	INO AC 250V, 3A	1	EN 60947-5-1	
SB2	EMERGENCY STOP	ALEPB25-1/C	INC AC 250V, 3A	1	IEC 144	CSA CE LR108205-2
SA	CAM SWITCH	AC-22A	AC600V 20A	1	IEC 60947-3	CSA CE UL



§11. Mechanical component part list

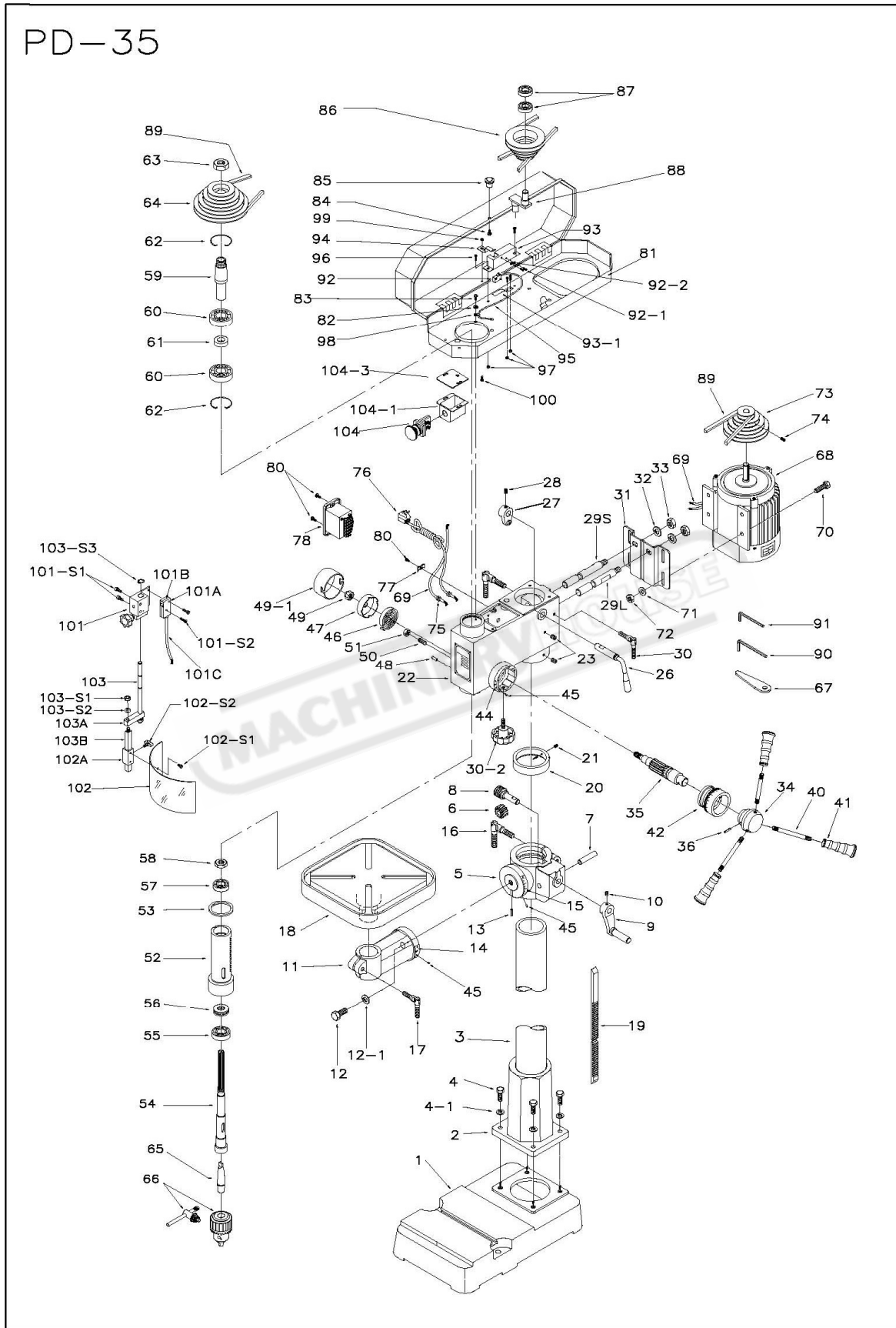

# PD-35B

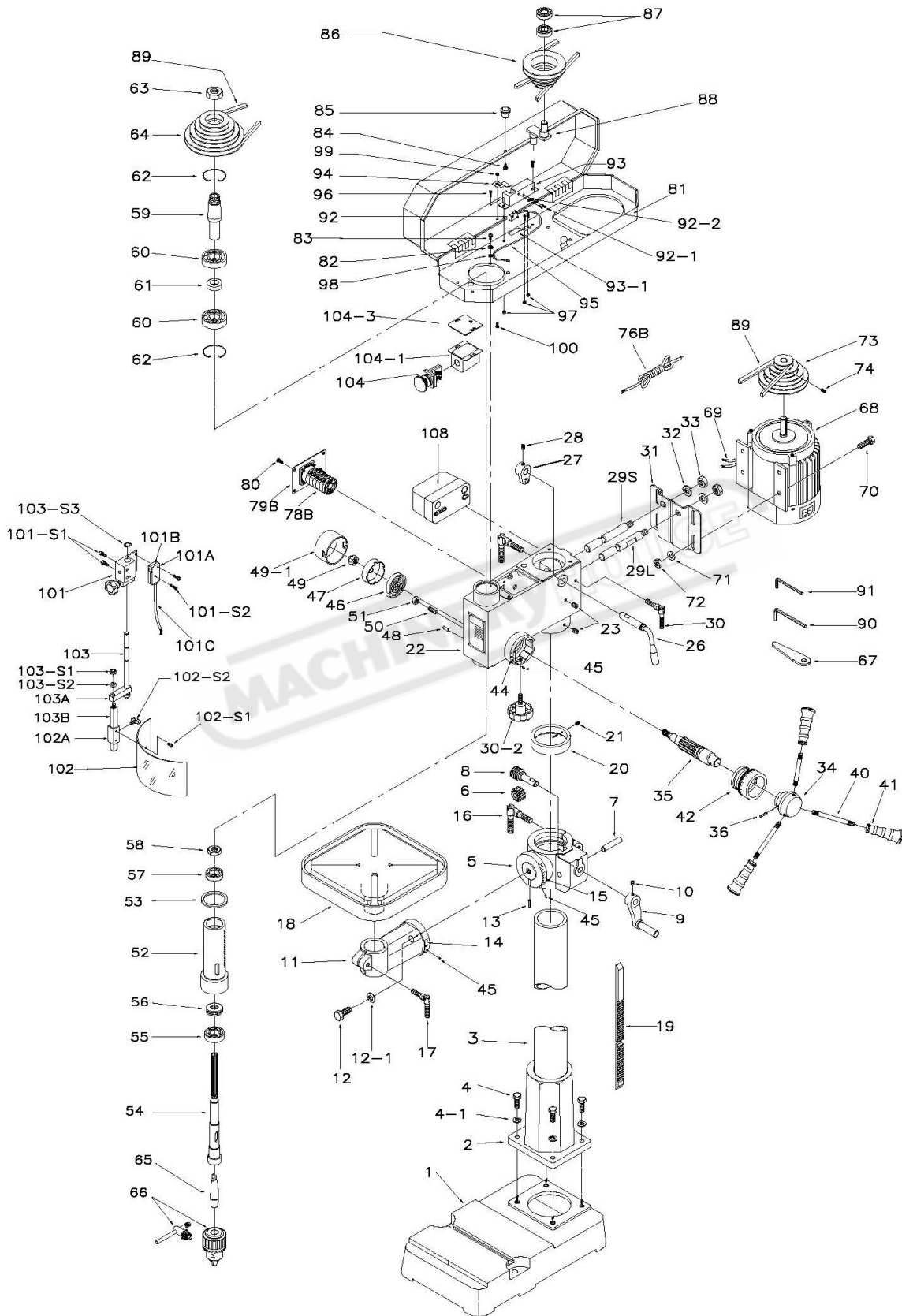

## 17

## PD-35 / PD-35B

## PARTS LIST

1	BASE
2	COLUMN HOLDER
3	COLUMN
4	BOLT
4-1	SPRING WASHER
5	TABLE BRACKET
6	GEAR
7	SHAFT
8	WORM
9	TABLE HANDLE
10	SET SCREW
11	TABLE ARM BRACKET
12	BOLT
12-1	SPRING WASHER
13	PIN
14	SCALE
15	ANGLE SCALE
16	CLAMP BOLT
17	TABLE BOLT
18	TABLE SWIVEL TYPE
19	RACK
20	RACK RING
21	SET SCREW
22	HEAD BODY
23	SET SCREW
26	SHAFT
27	SHIFTER
28	SET SCREW
29L	SLIDE BAR (L)
29S	SLIDE BAR (S)
30	LEAD BOLT
30-2	SCALE RING BOLT
31	MOTOR BASE
32	SPRING WASHER
33	NUT

34	HANDLE BODY
35	FEED SHAFT
36	ROLL PIN
40	FEED HANDLE
41	GRIP
42	SCALE RING
44	SCALE
45	RIVET
46	SPRING
47	SPRING CAP
48	PIN
49	NUT
49-1	FEED SHAFT COVER
50	SCREW
51	NUT
52	QUILL
53	RUBBER WASHER
54	SPINDLE
55	BALL BEARING
56	THRUST BEARING
57	BALL BEARING
58	SPINDLE NUT
59	SPINDLE SLEEVE
60	BALL BEARING
61	COLLAR
62	SNAP RING
63	PULLEY NUT
64	SPINDLE PULLEY
65	TAPER ARBOR
66	DRILL CHUCK
67	DRILL SHIFTER
68	MOTOR
69	MOTOR WIRE
70	BOLT
71	WASHER
72	NUT
73	MOTOR PULLEY
74	HEADLESS SET SCREW

